

Modular 2/4-Channel PID Temperature Controllers with Screw Connector



TMH Series CATALOG

For your safety, read and follow the considerations written in the instruction manual, other manuals and Autonics website.

The specifications, dimensions, etc are subject to change without notice for product improvement. Some models may be discontinued without notice.

Features

[Common]

- Easy maintenance with detachable body and base terminal
- Power supply and communication with expansion connectors (up to 32 units)

[TMH2/4 Series (Control Module)]

- Multi-channel (2-channel/4-channel) input and output control: Expandable up to 32 units (64-channels/128-channels)
- 50 ms high-speed sampling rate and $\pm 0.3\%$ measurement accuracy
- Simultaneous heating and cooling control function and auto/manual control mode (patent: Korea Patent Registration 10-1624105)

[TMHA (Analog Input / Output Option Module)]

- 4 channels, various input types/temperature ranges/transmission outputs
- 50 ms high-speed sampling rate and $\pm 0.3\%$ measurement accuracy

[TMHE (Digital Input / Alarm Output Option Module)]

- 8 digital inputs / 8 alarm outputs

[TMHCT (CT Input Option Module)]

- 8 CT inputs

[TMHC (Communication Modules)]

- Allows connection of control modules and option modules to master devices
- Connect up to 32 control/option modules per communication model

Ordering Information

This is only for reference, the actual product does not support all combinations. For selecting the specified model, follow the Autonics website.

■ Control module

T	M	H	①	-	②	2	③	④
---	---	---	---	---	---	---	---	---

① Channel

- 2: 2 channels
- 4: 4 channels

② Alarm output

- 2: Alarm output 1/2 (2 channels)
- 4: Alarm output 1/2/3/4 (2 channels)
- N: None (4 channels)

③ Control output

- R: Relay output
- S: SSR drive output
- C: Selectable current or SSR drive output

④ Module type

- B: Basic module
- E: Expansion module
- Since the expansion module is not supplied with power/comm. terminal. Use it with the basic module.

■ Option module

Model	Input	Output
TMHA-42AE	Temperature sensor / Analog input 1 to 4	Transmission output (0/4 - 20 mA) 1 to 4
TMHE-82RE	Digital input 1 to 8	Alarm output 1 to 8
TMHCT-82NE	CT input 1 to 8	-

■ Communication module

Model	Connection type	Protocol
TMHC-22LE	RS422, RS485	Modbus RTU, PLC Ladderless communication
TMHC-22EE	Ethernet (10/100baseT)	Modbus TCP

DAQMaster

- DAQMaster is comprehensive device management program. It is available for parameter setting, monitoring.
- Visit our website (www.autonics.com) to download the user manual and the program.

Specifications

■ Control module

Model	TMH2	TMH4
No. of channels	2 channels	4 channels
Sampling period	50 ms (2 channels or 4 channels synchronous sampling)	
Input specification	Thermocouple, RTD, Analog (refer to 'Input Specification')	
CT input	<ul style="list-style-type: none"> • 0.0 - 50.0A (primary current measurement range) • CT ratio: 1/1,000, • Measurement accuracy: $\pm 5\%$ F.S. ± 1 digit 	
Digital input	<ul style="list-style-type: none"> • Connect input ON: ≤ 1 kΩ, OFF: ≥ 100 kΩ • Solid state input Residual voltage: ≤ 0.9 V, Leakage current: ≤ 0.5 mA • Outflow current: ≈ 0.3 mA per input 	
Control type	Heating, cooling, heating & cooling: ON/OFF, P, PI, PD, PID control	
Control output	<ul style="list-style-type: none"> • Relay: 250 VAC ~ 3 A 1a mechanical life cycle: $\geq 10,000,000$ operations, electrical life cycle: $\geq 100,000$ operations • SSR: 12 VDC = ± 3 V, ≤ 20 mA • Current⁰¹⁾: DC 4 - 20 mA or DC 0 - 20 mA (Load: $\leq 500 \Omega$) 	
Alarm output	250 VAC ~ 3 A 1a Mechanical life cycle: $\geq 10,000,000$ operations Electrical life cycle: $\geq 100,000$ operations	
Communication	Modbus RTU	
Hysteresis	<ul style="list-style-type: none"> • Thermocouple / RTD: 1 to 100 (0.1 to 100) °C/°F • Analog: 1 to 100 digit 	
Proportional band (P)	<ul style="list-style-type: none"> • Thermocouple / RTD: 1 to 999 (0.1 to 999.9) °C/°F • Analog: 0.1 to 999.9 digit 	
Integral time (I)	0 to 9,999 sec	
Derivative time (D)	0 to 9,999 sec	
Control period (T)	<ul style="list-style-type: none"> • Relay output, SSR drive output: 0.1 to 120.0 sec • Selectable current or SSR drive output: 1.0 to 120.0 sec 	
Manual reset	0 to 100 (0.0 to 100.0) %	
Insulation type	Double insulation or reinforced insulation (mark: \square , dielectric strength between the measuring input part and the power part: 1 kV)	
Unit weight (packaged)	<ul style="list-style-type: none"> • Basic module: ≈ 178 g (≈ 251 g) • Expansion module: ≈ 173 g (≈ 246 g) 	

01) When the control output is set to the current output, the heater current value monitoring function through the CT input terminals is not available.

■ Option module



Model	TMHA-42AE
No. of channels	4 channels
Sampling period	50 ms (4 channels synchronous sampling)
Input specification	Thermocouple, RTD, analog (refer to 'Input Specification')
Transmission output	DC 4 - 20 mA or DC 0 - 20 mA (Load: $\leq 500 \Omega$)
Communication	Modbus RTU
Insulation type	Double insulation or reinforced insulation (mark: \square), dielectric strength between the measuring input part and the power part: 1 kV
Unit weight (packaged)	$\approx 161 \text{ g}$ ($\approx 234 \text{ g}$)

Model	TMHE-82RE	TMHCT-82NE
No. of channels	8 points	8 points
Input specification	<ul style="list-style-type: none"> - Digital input • Connect input ON: $\leq 1 \text{ k}\Omega$, OFF: $\geq 100 \text{ k}\Omega$ • Solid state input Residual voltage: $\leq 0.9 \text{ V}$, Leakage current: $\leq 0.5 \text{ mA}$ • Outflow current: $\approx 0.3 \text{ mA}$ per input 	<ul style="list-style-type: none"> - CT input • 0.0-50.0 A (primary current measurement range) • CT ratio: 1/1,000 • Measurement accuracy: $\pm 5\%$ F.S. ± 1 digit
Alarm output	250 VAC \sim 3 A 1a, <ul style="list-style-type: none"> • Mechanical life cycle: $\leq 10,000,000$ operations • Electrical life cycle: $\leq 100,000$ operations 	-
Communication	• Comm. terminal: RS485, • PC loader: TTL • Protocol: Modbus RTU,	
Insulation type	Double insulation or reinforced insulation (mark: \square), dielectric strength between the measuring input part and the power part: 1 kV	
Unit weight (packaged)	$\approx 166 \text{ g}$ ($\approx 239 \text{ g}$)	$\approx 148 \text{ g}$ ($\approx 221 \text{ g}$)

■ Communication module

Model	TMHC-22LE	TMHC-22EE
Communication	<ul style="list-style-type: none"> • Connection type: RS422 / RS485 • Protocol: Modbus RTU, PLC Ladderless communication 	<ul style="list-style-type: none"> • Connection type: Ethernet (10/100baseT) • Protocol: Modbus TCP
Insulation type	Double insulation or reinforced insulation (mark: \square), dielectric strength between the measuring input part and the power part: 1 kV	
Unit weight (packaged)	$\approx 147 \text{ g}$ ($\approx 219 \text{ g}$)	$\approx 129 \text{ g}$ ($\approx 200 \text{ g}$)

■ Common

Power supply⁰¹⁾	24 VDC \equiv
Allowable voltage range	90 to 110% of rated voltage
Power Consumption	$\leq 5 \text{ W}$ (for max. load)
Display type	None- parameter setting and monitoring is available at external devices
Memory retention	≈ 10 years (non-volatile semiconductor memory type)
Insulation resistance	100 M Ω (500 VDC \equiv megger)
Dielectric strength	1,000 VAC \sim 50/60 Hz for 1 min (between input terminals and power terminals)
Vibration	0.75mm amplitude at frequency of 5 to 55Hz (for 1 min) in each X, Y, Z direction for 2 hours
Noise immunity	Square shaped noise by noise simulator (pulse width 1 μs) $\pm 0.5 \text{ kV}$
Ambient temperature	-10 to 50 °C, storage: -20 to 60 °C (no freezing or condensation)
Ambient humidity	35 to 85%RH, Storage: 35 to 85%RH (no freezing or condensation)
Accessory	Expansion connector: 1, module lock connector: 2
Protection structure	IP20 (IEC standard)
Approval	CE,  ,  , 

01) The control extension/option/communication module uses the power voltage from the control basic module.

Communication Setting



■ Interface

Module	Control	Option	Communication	
Series	TMH2/4	TMHA, TMHE, TMHCT	TMHC-22LE	TMHC-22EE
Protocol	Modbus RTU		Modbus RTU, PLC Ladderless	Modbus TCP
Comm. method	RS485		RS422, RS485	Ethernet (10/100BaseT)
Maximum connection	32 units (address: 01 to 32) • 16 units in case of connecting TMHC module (address: 01 to 16)	16 units per each module	Control module 16 units, option module 16 units per each module (32 units in total)	
Synchronization type	Asynchronous		-	
Connection method	Two-wire half duplex		-	
Comm. effective range	$\leq 800 \text{ m}$		-	
Comm. speed	4,800 / 9,600 (default) / 19,200 / 38,400 / 115,200 bps (parameter)		10/100 Mbps	
Response time	5 to 99 ms (default: 20 ms)		-	
Start bit	1 bit (fixed)		-	
Data bit	8 bit (fixed)		-	
Parity bit	None (default) , Odd, Even		-	
Stop bit	1 bit, 2 bit (default)		-	
EEPROM life cycle	<ul style="list-style-type: none"> • TMH2/4, TMHC-22LE: $\approx 1,000,000$ operations (Erase / Write) • Other models: Not applicable 			

- When changing the setting value related to communication interface, reboot the device for normal operation.
- It is recommended to use Autonics communication converter. Please use twisted pair wire, which is suitable for RS485 communication.

■ Address

Set the communication address with the communication address setting switch (SW1, default: 1) and communication address group switch (SW2, default: +0, TMH2/4 series).

Series	SW1																
	0	1	2	3	4	5	6	7	8	9	A	B	C	D	E	F	
TMH2/4		16	01	02	03	04	05	06	07	08	09	10	11	12	13	14	15
		32	17	18	19	20	21	22	23	24	25	26	27	28	29	30	31
TMHC	16	01	02	03	04	05	06	07	08	09	10	11	12	13	14	15	
TMHA	48	33	34	35	36	37	38	39	40	41	42	43	44	45	46	47	
TMHE	64	49	50	51	52	53	54	55	56	57	58	59	60	61	62	63	
TMHCT	80	65	66	67	68	69	70	71	72	73	74	75	76	77	78	79	

- When connecting TMHC and TMH2/4 to master separately, communication address can be duplicated, but if they communicate with master at the same time, communication address must not be duplicated to avoid error. (use address TMHC: 1 to 16, TMH2/4: 17 to 32)

Input Specifications

Input type and range

The setting range of some parameters is limited when using the decimal point display.

Input type	Decimal point	Display Method	Input range (°C)	Input range (°F)	
Thermo-couple	K (CA)	K (CA).H	-200 to 1,350	-328 to 2,463	
		K (CA).L	-200.0 to 1,350.0	-328.0 to 2,463.0	
	J (IC)	J (IC).H	-200 to 800	-328 to 1,472	
		J (IC).L	-200.0 to 800.0	-328.0 to 1,472.0	
	E (CR)	E (CR).H	-200 to 800	-328 to 1,472	
		E (CR).L	-200.0 to 800.0	-328.0 to 1,472.0	
	T (CC)	T (CC).H	-200 to 400	-328 to 752	
		T (CC).L	-200.0 to 400.0	-328.0 to 752.0	
	B (PR)	1	B (PR)	0 to 1,800	32 to 3,272
	R (PR)	1	R (PR)	0 to 1,750	32 to 3,182
	S (PR)	1	S (PR)	0 to 1,750	32 to 3,182
	N (NN)	1	N (NN)	-200 to 1,300	-328 to 2,372
	C (TT)	1	C (TT)	0 to 2,300	32 to 4,172
	G (TT)	1	G (TT)	0 to 2,300	32 to 4,172
	L (IC)	L (IC).H	-200 to 900	-328 to 1,652	
		L (IC).L	-200.0 to 900.0	-328.0 to 1,652.0	
U (CC)	U (CC).H	-200 to 400	-328 to 752		
	U (CC).L	-200.0 to 400.0	-328.0 to 752.0		
RTD	Platinel II	1	PLII	0 to 1,390	32 to 2,534
	Cu50 Ω	0.1	CU50	-200.0 to 200.0	-200.0 to 392.0
	Cu100 Ω	0.1	CU100	-200.0 to 200.0	-200.0 to 392.0
	JPt100 Ω	1	JPt100.H	-200 to 650	-328 to 1,202
	JPt100 Ω	0.1	JPt100.L	-200.0 to 650.0	-328.0 to 1,202.0
	DPt50 Ω	0.1	DPt50.L	-200.0 to 600.0	-328.0 to 1,202.0
	DPt100 Ω	1	DPt100.H	-200 to 650	-328 to 1,202
	DPt100 Ω	0.1	DPt100.L	-200.0 to 650.0	-328.0 to 1,202.0
	Nickel120 Ω	1	NI12	-80 to 260	-112 to 500
	Analog	0 to 10 V	-	AV1	0 ~ 10 V
0 to 5 V		-	AV2	0 ~ 5 V	
1 to 5 V		-	AV3	1 ~ 5 V	
0 to 100 mV		-	AMV1	0 ~ 100 mV	
0 to 20 mA		-	AMA1	0 ~ 20 mA	
4 to 20 mA		-	AMA2	4 ~ 20 mA	

• Permissible line resistance per line: ≤ 5 Ω

Measurement accuracy

Input type	Using temperature	Measurement accuracy
Thermo-couple	At room temperature (23 ± 5 °C)	(PV ± 0.3% or ± 1 °C higher one) ± 1-digit • Thermocouple K, J, T, N, E below -100 °C and L, U, PLII, RTD Cu50 Ω, DPt50 Ω: (PV ± 0.3% or ± 2 °C higher one) ± 1-digit • Thermocouple C, G and R, S below 200 °C: (PV ± 0.3% or ± 3 °C higher one) ± 1-digit • Thermocouple B below 400 °C: there is no accuracy standards
	Out of room temperature range	(PV ± 0.5% or ± 2 °C higher one) ± 1-digit • RTD Cu50 Ω, DPt50 Ω: (PV ± 0.5% or ± 3 °C higher one) ± 1-digit • Thermocouple R, S, B, C, G: (PV ± 0.5% or ± 5 °C higher one) ± 1-digit • Other sensors: ≤ ± 5 °C (≤ -100 °C)
RTD	At room temperature (23 ± 5 °C)	± 0.3% F.S. ± 1-digit
	Out of room temperature range	± 0.5% F.S. ± 1-digit
Analog	At room temperature (23 ± 5 °C)	± 0.3% F.S. ± 1-digit
	Out of room temperature range	± 0.5% F.S. ± 1-digit

• Connecting 1 or more expansion module can vary measurement accuracy about ± 1°C, regardless of the number of connected expansion module.

Dimensions

• Unit: mm, For the detailed drawings, follow the Autonics website.

Side

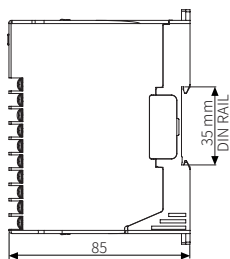

Front

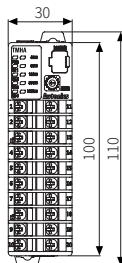

Inside

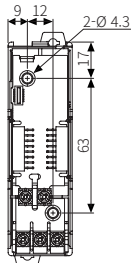

Unit Descriptions

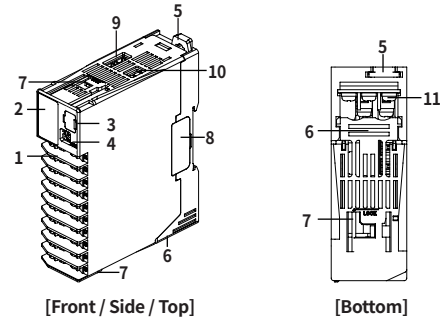

[Front / Side / Top]

[Bottom]

1. Input / Output Terminal

Refer to 'Connection' for the details about terminal description.

2. Indicator

- Control module: TMH2

Indicator	Status	Initial power ON ⁽⁰¹⁾	Control output	Auto tuning ⁽⁰²⁾	Alarm output	
					N.O.	N.C
LED 1 LED 2	PWR (green) ⁽⁰³⁾	-	ON	ON	-	-
PWR	CH1 (red)	-	ON	Flash	-	-
	CH2 (red)	-	ON	Flash	-	-
CH 1	(red)	-	ON ⁽⁰⁴⁾	OFF	-	-
	AL1 (red)	-	ON ⁽⁰⁵⁾	OFF	-	-
CH 2	(yellow)	Flash (4,800 bps)	Module communication status ⁽⁰⁶⁾			
	AL2 (yellow)	Flash (9,600 bps)	-	-	OFF	ON
AL 3	AL2 (yellow)	Flash (19,200 bps)	-	-	OFF	ON
	AL3 (yellow)	Flash (38,400 bps)	-	-	OFF	ON
AL 4	AL4 (yellow)	Flash (115,200 bps)	-	-	OFF	ON

- Control module: TMH4

Indicator	Status	Initial power ON ⁽⁰¹⁾	Control output	Auto tuning ⁽⁰²⁾
LED 1 LED 2	PWR (green) ⁽⁰³⁾	-	ON	ON
PWR	CH1 (red)	-	ON	Flash
	CH2 (red)	-	ON	Flash
CH 1	CH3 (red)	-	ON	Flash
	CH4 (red)	-	ON	Flash
CH 2	(yellow)	Flash (4,800 bps)	Module communication status ⁽⁰⁶⁾	
	(yellow)	Flash (9,600 bps)	-	-
CH 3	(yellow)	Flash (19,200 bps)	-	-
	(yellow)	Flash (38,400 bps)	-	-
CH 4	(yellow)	Flash (115,200 bps)	-	-

- Option module: TMHA [Analog input / output]

Indicator	Status	Initial power ON ⁽⁰¹⁾	Internal comm.	Transmission output
LED 1 LED 2	PWR (green) ⁽⁰⁷⁾	-	ON	ON
PWR	CH1 (red)	-	-	ON
	CH2 (red)	-	-	ON
CH 1	CH3 (red)	-	-	ON
	CH4 (red)	-	-	ON
CH 2	(yellow)	Flash (4,800 bps)	Module communication status ⁽⁰⁶⁾	
	(yellow)	Flash (9,600 bps)	ON (CH1)	-
CH 3	(yellow)	Flash (19,200 bps)	ON (CH2)	-
	(yellow)	Flash (38,400 bps)	ON (CH3)	-
CH 4	(yellow)	Flash (115,200 bps)	ON (CH4)	-

- Option module: TMHE [Digital input, Alarm output]

Indicator	Status	Initial power ON ⁽⁰¹⁾	Internal comm.	Alarm output			
				N.O.	N.C.	Open	Closed
LED 1 LED 2	PWR (green) ⁽⁰⁷⁾	-	ON	ON	-	-	-
PWR	AL1 (red)	-	-	OFF	ON	OFF	ON
	AL2 (red)	-	-	OFF	ON	OFF	ON
AL 1	AL3 (red)	-	-	OFF	ON	OFF	ON
	AL4 (red)	-	-	OFF	ON	OFF	ON
AL 2	(yellow)	Flash (4,800 bps)	Module communication status ⁽⁰⁶⁾				
	AL5 (yellow)	Flash (9,600 bps)	-	OFF	ON	OFF	ON
AL 3	AL6 (yellow)	Flash (19,200 bps)	-	OFF	ON	OFF	ON
	AL7 (yellow)	Flash (38,400 bps)	-	OFF	ON	OFF	ON
AL 4	AL8 (yellow)	Flash (115,200 bps)	-	OFF	ON	OFF	ON

- Option module: TMHCT [CT input]

Indicator	Status	Initial power ON ⁽⁰¹⁾	CT input ⁽⁰⁸⁾	Internal comm.
LED 1 LED 2	PWR (green) ⁽⁰⁷⁾	-	ON	ON
PWR	(red)	-	ON (40.1 to 50.0 A)	-
	(red)	-	ON (30.1 to 40.0 A)	-
(red)	(red)	-	ON (20.1 to 30.0 A)	-
	(red)	-	ON (10.1 to 20.0 A)	-
(yellow)	(yellow)	Flash (4,800 bps)	Module communication status ⁽⁰⁶⁾	
	(yellow)	Flash (9,600 bps)	ON (40.1 to 50.0 A)	-
(yellow)	(yellow)	Flash (19,200 bps)	ON (30.1 to 40.0 A)	-
	(yellow)	Flash (38,400 bps)	ON (20.1 to 30.0 A)	-
(yellow)	(yellow)	Flash (115,200 bps)	ON (10.1 to 20.0 A)	-

- Communication module: TMHC-22LE [Ladderless communication]

Indicator	Status	Initial power ON ⁰⁹⁾	Internal comm.	Connection	Ladderless communication
LED 1 LED 2 PWR	PWR (green)	Flash (4,800 bps)	Flash (green)		Flash (red, read operation)
	(red)	Flash (9,600 bps)	Flash (TMH2/4)		-
	(red)	Flash (19,200 bps)	Flash (TMHA)		-
	(red)	Flash (38,400 bps)	Flash (TMHE)		-
	(red)	Flash (115,200 bps)	Flash (TMHCT)		-
LED 2	(yellow)	Flash (4,800 bps)		ON	Flash (send operation)
	(yellow)	Flash (9,600 bps)		ON (TMH2/4)	-
	(yellow)	Flash (19,200 bps)		ON (TMHA)	-
	(yellow)	Flash (38,400 bps)		ON (TMHE)	-
	(yellow)	Flash (115,200 bps)		ON (TMHCT)	-

- Communication module: TMHC-22EE [Ethernet communication]

Indicator	Status	Initial power ON	Internal comm.	Connection
LED 1 LED 2 PWR	PWR (green)	ON	Flash (external device)	
	(red)	-	Flash (TMH2/4)	
	(red)	-	Flash (TMHA)	
	(red)	-	Flash (TMHE)	
	(red)	-	Flash (TMHCT)	
LED 2	(yellow)	-	ON	Flash (Ethernet comm.)
	(yellow)	-	-	ON (TMH2/4)
	(yellow)	Sequence-flashing vertically for 5 sec	-	ON (TMHA)
	(yellow)	-	-	ON (TMHE)
	(yellow)	-	-	ON (TMHCT)

- 01) At the moment when power is on, the indicator of set communication speed flashes for 5 sec.
 02) Indicator of the channel, which is in the process of auto-tuning, flashes at 1 sec interval.
 03) When communicating with external device, PWR indicator flashes.
 04) Turns on, when CH1 outputs cooling control in the heating&cooling control method.
 05) Turns on, when CH2 outputs cooling control in the heating&cooling control method.
 06) • ON: Internal comm. (normal) • Flash: Internal comm. (abnormal) • OFF: not communicating
 07) • 1 sec interval flash: external comm. (normal) • ON: Internal comm. (normal) • Flash: Internal comm. (abnormal)
 • OFF: not Internal communicating
 08) The indicator corresponding to the certain setting value of CT input flashes according to the parameter.
 • LED 1: CT Input Value Indication Lamp1 • LED 2: CT Input Value Indication Lamp2
 09) At the moment when power is ON, the indicator of communication speed flashes for 5 sec at 1 sec interval.
 • LED 1: HOST 1 • LED 2: HOST 2

3. PC loader port

PC loader port supports serial communication between single module and PC. It needs communication converter for communicating.

4. Communication address setting switch (SW1)

Set the communication address. If changing the communication address by setting switch, use the flat head driver which is 2mm size or plastic driver. If not, it may cause product damage.

5. Rail lock

Rail lock helps installing the device. Refer to 'Installation Method' for the details.

6. Lock lever

Lock lever holds module body and base tightly.

7. Module lock connector hole

When connecting modules, insert module lock connector in the hole in order to enhance coherence between them.

8. END Cover

When connecting modules, remove END cover in order to connect expansion connector.

9. CT input Terminal [Control module]

Refer to 'Connection' for the details.

9. Communication mode switch (SW2) [Ladderless communication module]

Select communication mode between RS485 and RS422.

10. Communication address group switch (SW2) [Control module]

When setting the communication address over 16, select +16.

11. Power / Communication terminal [Control basic module]

Supplies power to both basic control/expansion module and communicates with one or more module.

Sold Separately

- Communication converter: SCM-series
- CT connector cable: CICT4-□
- Current transformer (CT)